

# Gas Safety and Control Technology for Power Generation and Domestic, Commercial and Industrial Gas Fired Equipment

Karl Dungs Inc.

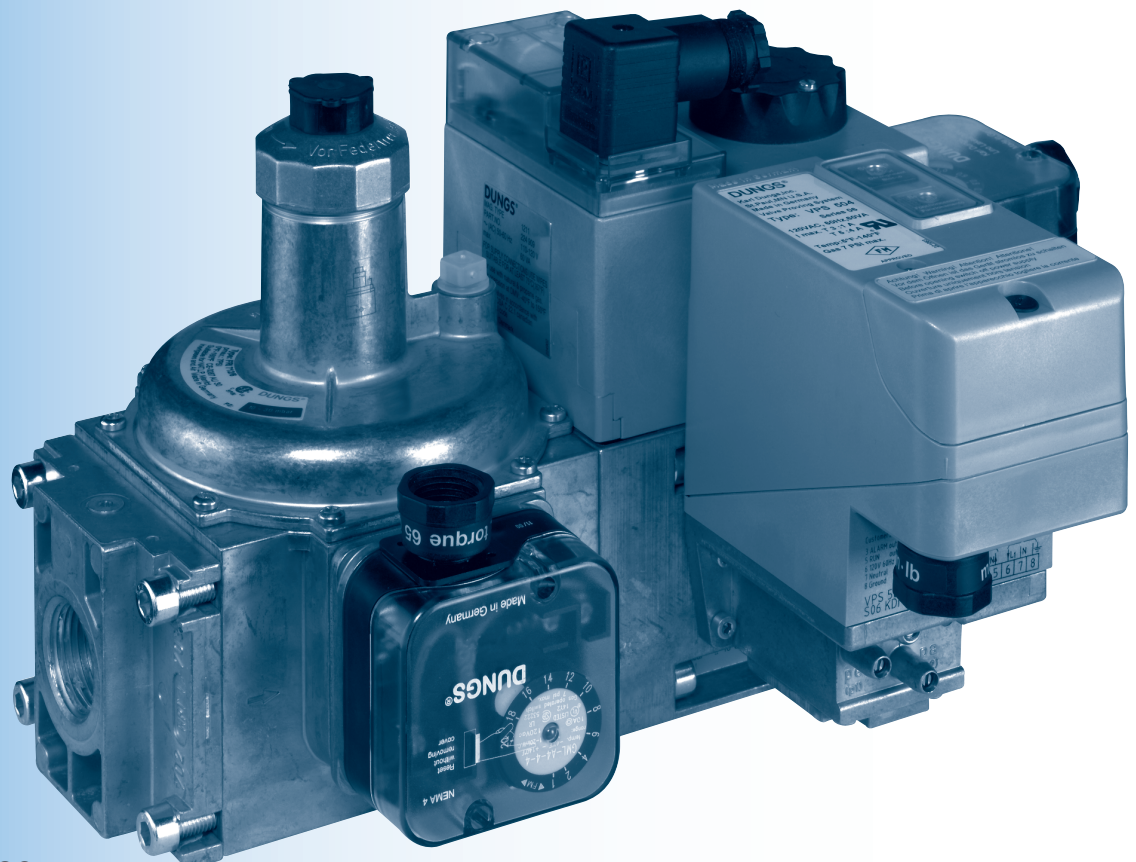

Karl Dungs is an ISO 9001  
manufacturing facility.

**Gas Safety and Control Technology  
for Power Generation and  
Domestic, Commercial and  
Industrial Gas Fired Equipment**



 **Karl Dungs GmbH & Co. KG Headquarters  
Urbach, Germany**



Dungs has over 500 employees manufacturing DUNGS products in three factories. These products, which comply with high safety requirements, are used in gas fired systems throughout the world.

DUNGS products are suitable for all industrial combustion gases, non-corrosive gases and air. Free of non-ferrous metal versions are suitable for gases with max. 0,1 Vol.% H<sub>2</sub>S, dry (sewer or bio gases).

 **Karl Dungs Inc.  
Blaine, Minneapolis U.S.A.**



- Skilled staff in U.S.A. available
- Spare parts in stock
- Customized modification of products
- Nationwide Representatives in North America

**Scope of Supply**

**Safety Shutoff Valves**

- Single Safety Shutoff
- Dual Safety Shutoff
- Combination Regulator and Dual Safety Shutoff

**Regulators**

- Gas Appliance Regulators
- Line Pressure Regulators
- Proportionators and Zero Governors

**Limit Controls**

- Gas Pressure Switches
- Air Pressure Switches

**Valve Proving and Valve Position Indication**

- Valve Proving Systems
- Proof of Closure Switches
- Closed Position Indicators
- Visual Indicators

**Flow Control and Burner Accessories**

- Butterfly Valves
- Manually Operated Shutoff Valves
- Electric Actuators
- Gas Orifice Meters and Venturis
- Ignition Transformers

- Automatic Gas Burner Controls (CE)
- UV Sensors (CE)
- Control Units (CE)
- Analog Pressure Sensors (CE)
- Vent Valves (CE)

- Control Cabinets (CE)
- Prepipe Valve Trains

**CE Check model listing for specific approvals**

|           |  |      |
|-----------|--|------|
| <b>1</b>  | <b>GasMultiBloc<sup>®</sup> / MBC</b> .....  | 4    |
| <b>2</b>  | <b>Pre-mix-WhirlWind System / MBC, GB-WND</b> .....                                    | 5    |
| <b>3</b>  | <b>Dual Modular Valves / DMV</b> .....   | 6-8  |
| <b>4</b>  | <b>Single Valves / SV, MV</b> .....  | 9-10 |
| <b>5</b>  | <b>Valve Proving Systems / VDK, VPS</b> .....  | 11   |
| <b>6</b>  | <b>Gas Pressure Switches / GAO, GMH, GML</b> .....                                     | 12   |
| <b>7</b>  | <b>Differential Air Pressure Switches / AA</b> .....                                   | 13   |
| <b>8</b>  | <b>Pressure Regulators and Ratio Regulators / Zero Governors / FRS, FRI, FRG</b> ..... | 14   |
| <b>9</b>  | <b>Modulating Control Valves &amp; Motors / DMK, DMA</b> .....                         | 15   |
| <b>10</b> | <b>Modular System</b> .....  | 16   |
| <b>11</b> | <b>Pre-Piped Valve Trains</b> .....  | 17   |
| <b>12</b> | <b>Gas Flow Controls &amp; Burner Accessories</b> .....                                | 18   |

The DUNGS MBC... MultiBloc integrates filter, two safety shutoff valves and servo pressure regulator in one compact unit:

- Dirt trap and Microfilter
- Safety shutoff valves rated for 5 PSI
- Servo pressure regulator unit to ANSI Z21.18 / CSA 6.3
- Outlet pressure: 0 - 4 PSI
- Precision regulation of outlet pressure for optimal outlet pressure stability

- Flanged joints with pipe threads to ISO 7/1 or NPT
- Easy to install
- Light weight
- Available in 12 VDC, 24 VDC, 24 VAC and 120 VAC

The MultiBloc permits individual solutions with valve proving system and min./max. pressure switches. High flow rates with low pressure drops.

## Application

The MBC is intended for forced air burners and premix burners in conjunction with mechanical or electronic integrated gas-air regulation units. Suitable for natural, LP and butane gas.

## Specifications

|                                  |   |
|----------------------------------|---|
| Pipe size / Thread               | 1/2" - 2" NPT or Rp                           |
| Max. operating pressure          | 5 PSI   |
| Max. close-off pressure          | 10 PSI  |
| Electrical ratings (+10% / -15%) | 12 VDC, 24 VDC, 24 VAC and 120 VAC            |
| Enclosure rating                 | NEMA 1  |
| Operating time                   | 100 % Duty Cycle                              |
| Closing time                     | < 1 s   |
| Opening time (to max. flow)      | < 1 s   |
| Ambient temperature rating       | -40 °F to +140 °F (CSA); 0 °F to 140 °F (UL)  |
| Installation position            | Horizontal for optimal regulatory performance |



The GB-WND series combination control valve and the MBC-WND WhirlWind series multifunctional control valve integrate two safety shutoff valves, a zero governor and a swirl plate assembly, that premix gas and air when used with a pre-mix blower

The two safety shutoff valves shut the gas flow when de-energized. The zero governor regulates the outlet pres-

sure to 0" W.C. or slightly less than 0" W.C. signal. The swirl plate assembly utilizes turbine technology to achieve exceptionally low fire stability and gas and air mixing, which can result in high turndowns.

These controls include low fire zero point correction of gas/air ratio at zero governor and main flow adjustment, which reduces the high fire flow to

desired capacity and allows a natural gas burner to be converted for LP gas by simply turning the adjustment; no replacement orifice required.

### Application

For pre-mix burners and forced-draft burners. Suitable for natural gas, propane gas and air.

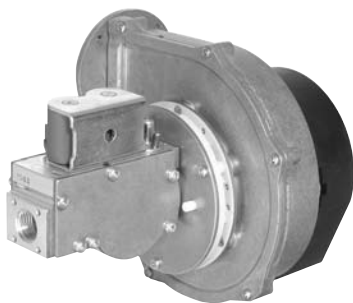
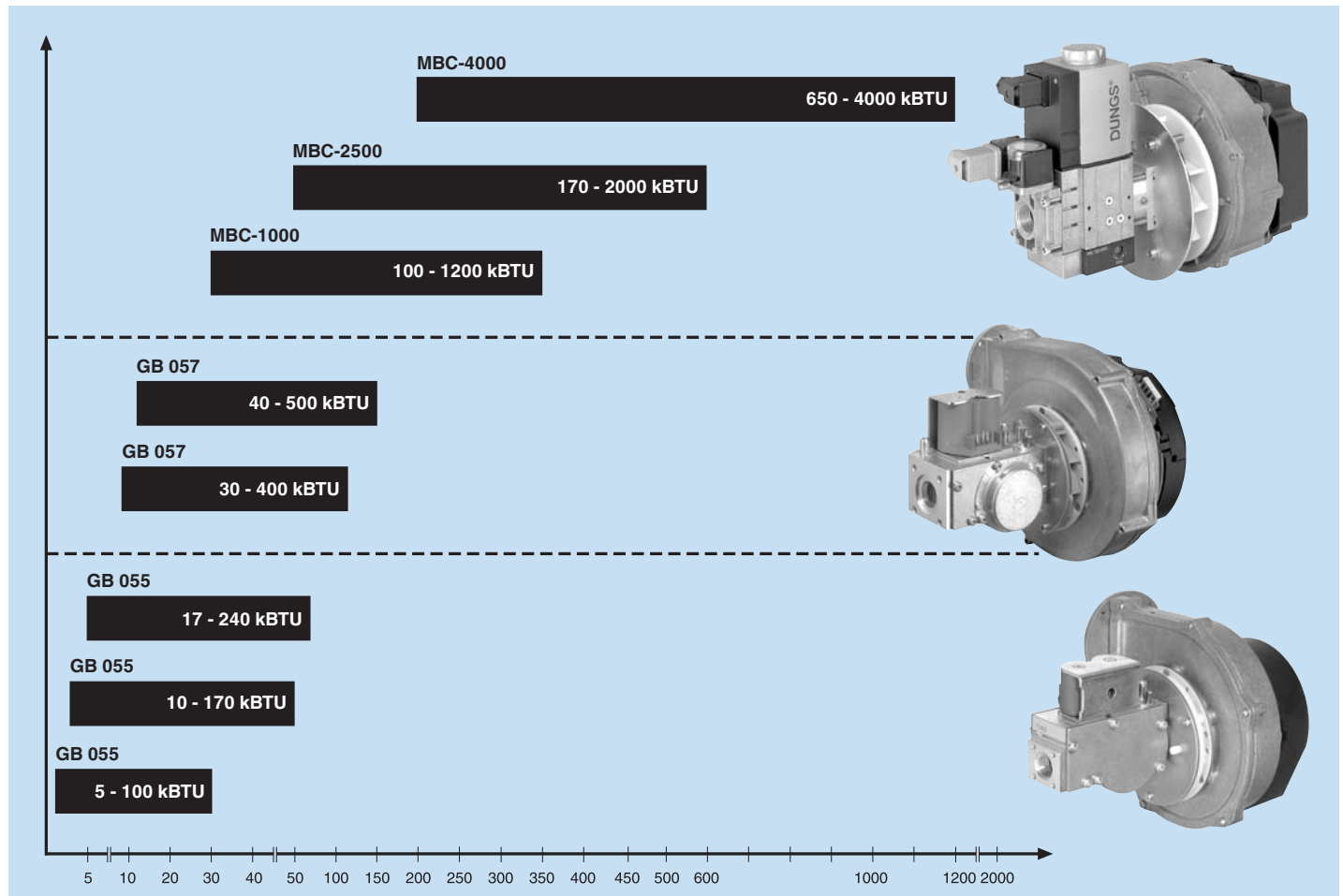

GB-WND 055

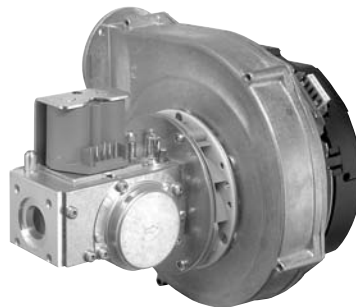

GB-WND 057

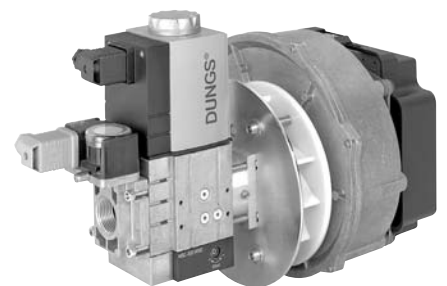

MBC 1000/602

The Dual Modular Valve (DMV) combines two safety shutoff valves (which can be wired independently or in parallel) in one compact housing.

- Valve 1 (V1) of the DMV-D and DMV-DLE series is fast opening and fast closing.

- Valve 2 (V2) of the DMV-D is fast opening, while V2 of the DMV-DLE is slow-opening for smoother light-off.
- Max. flow adjustment on V2 provides variable main flow on both models.

### Application

This DMV is recommended for industrial and commercial heating applications that require two safety shutoff valves in series. The DMV is suitable for natural gas, propane, butane, air and other inert gases.

## Specifications

|   |  |
|---|--|
| <b>Pipe size / Thread</b>                               | 1/2" - 2" NPT or Rp Threaded<br>DN 40 - 125 ISO Flanged                                      |
| <b>Max. operating pressure</b>                          | 7 PSI (UL, FM); 5 PSI (CSA)  |
| <b>Max. close-off pressure</b>                          | 7 PSI (UL, FM); 5 PSI (CSA)  |
| <b>Electrical ratings (+10% / -15%)</b>                 | 24 VAC, 120 VAC and 24 VDC   |
| <b>Enclosure rating</b>                                 | NEMA Type 12 (/602) or NEMA Type 4x (/604)   |
| <b>Operating time</b>                                   | 100 % duty cycle   |
| <b>Closing time</b>                                     | < 1 s  |
| <b>Opening time (to max. flow)</b>                      | DMV-D: V1 & V2 < 1 s<br>DMV-DLE: V1 < 1 s; V2 Adjustable 10 - 20 s @ 70 °F                   |
| <b>Ambient temperature rating</b>                       | -40 °F to +150 °F (-40 °C to +65 °C) NEMA 12<br>-20 °F to +140 °F (-30 °C to +60 °C) NEMA 4x |
| <b>Max. flow adjustment</b>                             | Adjustable on V2: approx. <10 to 100 % of stroke   |
| <b>Installation position</b>                            | Safety valve upright vertical to horizontal  |
| <b>Test ports &amp; system accessory mounting ports</b> | G 1/8 ISO 228 ports available on both sides.<br>See sales literature for valve specifics.    |
| <b>Capacities @ 2 in. W.C. pressure drop</b>            | 450 - 15,000 CFH Natural Gas   |

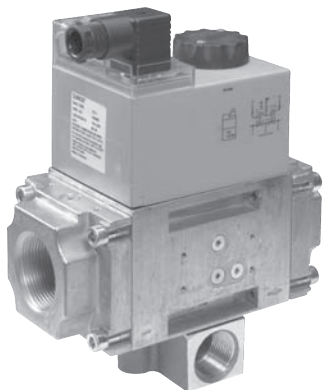

DMV-D 702/602 with Vent Line Adapter

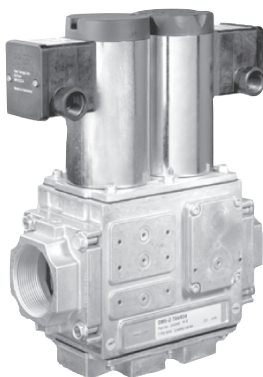

DMV-D 704/604



DMV-DLE 5100/11

The Dual Modular Valve (DMV) combines two safety shutoff valves (which can be wired independently or in parallel) in one compact housing.

- Valve 1 (V1) of the DMV-D and DMV-DLE series is fast opening and fast closing.
- Valve 2 (V2) of the DMV-D is fast opening, while V2 of the DMV-DLE is slow-opening for smoother light-off. Max. flow adjustment on V2 provides variable main flow on both models.

- Valve 2 (V2) incorporates proof of closure (POC) on models designated /622 & /624.
- Valves 1 & 2 (V1 & V2) incorporate proof of closure on models /634.

### Application

This DMV is recommended for industrial and commercial heating applications that require two safety shutoff valves in series with POC. The DMV is suitable for natural gas, propane, butane, air and other inert gases.

## Specifications

|   |   |
|---|---|
| <b>Pipe size / Thread</b>                               | 1/2" - 2" NPT or Rp   |
| <b>Max. operating pressure</b>                          | 7 PSI (UL, FM); 5 PSI (CSA)   |
| <b>Max. close-off pressure</b>                          | 7 PSI (UL, FM); 5 PSI (CSA)   |
| <b>Electrical ratings (+10% / -15%)</b>                 | 120 VAC @ 50 - 60 Hz (others available depending on body size)  |
| <b>Enclosure rating</b>                                 | NEMA Type 12 (/622) or NEMA Type 4x (/624 & /634)   |
| <b>Operating time</b>                                   | 100 % duty cycle  |
| <b>Closing time</b>                                     | < 1 s   |
| <b>Opening time (to max. flow)</b>                      | DMV-D: V1 & V2 < 1 s<br>DMV-DLE: V1 < 1 s; V2 Adjustable 10 - 20 s @ 70 °F  |
| <b>Ambient temperature rating</b>                       | -40 °F to +150 °F (-40 °C to +65 °C) NEMA 12<br>-20 °F to +140 °F (-30 °C to +60 °C) NEMA 4x  |
| <b>Max. flow adjustment</b>                             | Adjustable on V2: approx. <10 to 100 % of stroke  |
| <b>Installation position</b>                            | Safety valve upright vertical to horizontal   |
| <b>Test ports &amp; System accessory mounting ports</b> | G 1/8 ISO 228 ports available on both sides.<br>See sales literature for valve specifics.   |
| <b>Proof of Closure Switch</b>                          | Factory mounted & calibrated; SPDT switch with indication lamps;<br>- AC max. 10 A resistive @ 120 VAC<br>- AC max. 8 A inductive @ 120 VAC |
| <b>Capacities @ 2 in. W.C. pressure drop</b>            | 450 - 4,000 CFH Natural Gas   |

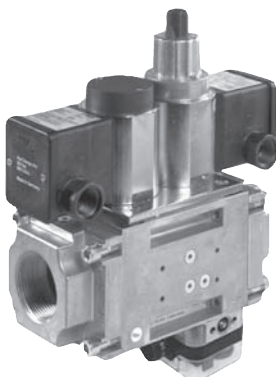

DMV-DLE 702/624

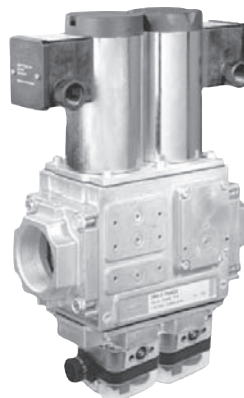

DMV-D 704/634

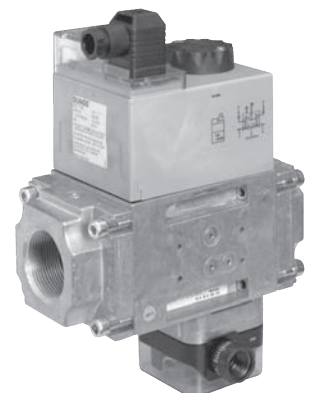

DMV-D 702/622

The Two-Stage Dual Modular Valve (DMV-ZR) combines two safety shutoff valves (which can be wired independently or in parallel) in one compact housing.

- Valve 2 incorporates two stages, which can be set at two different firing rates. Both firing rates are field adjustable and can modulate from high to low during burner operation.

- Valve 1 (V1) of the DMV-D and DMV-DLE series is fast opening and fast closing.
- Valve 2 (V2) of the DMV-D is fast opening, while V2 of the DMV-DLE is slow-opening for smoother light-off. Max. flow adjustment on V2 provides variable main flow on both models.
- Valve 1 (V1) incorporates proof of closure (POC) on models designated /612.

#### Application

This DMV-ZR is recommended for industrial and commercial heating applications, where two safety shutoff valves and modulating between two firing rates is required. The DMV-ZR Dual Modular Valve two stage is suitable for natural gas, propane, butane, air and inert gases.

## Specifications

|   |   |
|---|---|
| <b>Pipe size / Thread</b>                               | 1/2" - 2" NPT or Rp   |
| <b>Max. operating pressure</b>                          | 7 PSI (UL, FM); 5 PSI (CSA)   |
| <b>Max. close-off pressure</b>                          | 7 PSI (UL, FM); 5 PSI (CSA)   |
| <b>Electrical ratings (+10% / -15%)</b>                 | 110 - 120 VAC @ 50 - 60 HZ (others available depending on body size)  |
| <b>Enclosure rating</b>                                 | NEMA Type 12 (/602)   |
| <b>Operating time</b>                                   | 100 % duty cycle  |
| <b>Closing time</b>                                     | < 1 s   |
| <b>Opening time (to max. flow)</b>                      | DMV-ZRD: V1 & V2 < 1 s<br>DMV-ZRDLE: V1 < 1 s; V2 Adjustable 10 - 20 s @ 70 °F  |
| <b>Ambient temperature rating</b>                       | -20 °F to +150 °F (-30 °C to +65 °C)  |
| <b>Max. flow adjustment</b>                             | Adjustable on V2, stage one: approx. 5 to 30 % of stroke<br>Adjustable on V2, stage two: approx. 20 to 100 % of stroke                      |
| <b>Installation position</b>                            | Safety valve upright vertical to horizontal   |
| <b>Test ports &amp; System accessory mounting ports</b> | G 1/8 ISO 228 ports available on both sides.<br>See sales literature for valve specifics.   |
| <b>Proof of Closure Switch (/612 models only)</b>       | Factory mounted & calibrated; SPDT switch with indication lamps;<br>- AC max. 10 A resistive @ 120 VAC<br>- AC max. 8 A inductive @ 120 VAC |
| <b>Capacities @ 2 in. W.C. pressure drop</b>            | 450 - 3,000 CFH Natural Gas   |

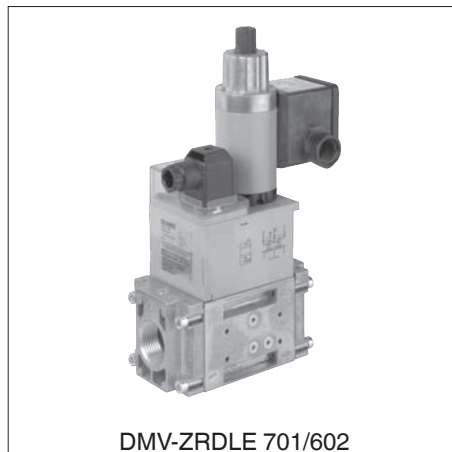

DMV-ZRDLE 701/602

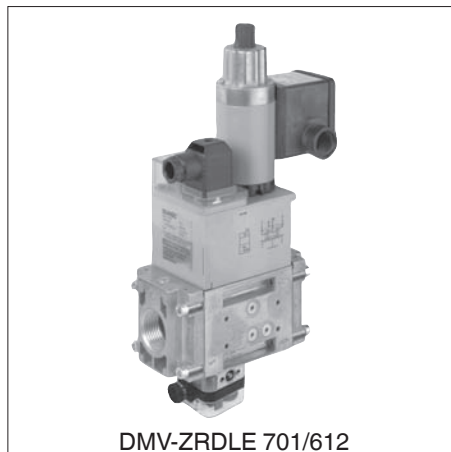

DMV-ZRDLE 701/612



The automatic shutoff valve SV is a single-stage safety shut-off valve for gas burners and gas burning appliances:

- SV series are fast opening and closing
- SV-DLE series are slow opening and fast closing.
- Models ending in /614 integrated proof of closure. Models ending in /604 are of the non-proof of closure type.

- All models pipe thread on inlet side and threaded flange on outlet side.
- An additional threaded flange on inlet side is optional

### Application

The SV is recommended for industrial and commercial heating applications that require a safety shutoff valve incorporating proof of closure. The SV is suitable for natural gas, propane, butane, air and inert gases.

## Specifications

|   |   |
|---|---|
| Pipe size / Thread                              | 1/2" - 2" NPT or Rp   |
| Max. operating pressure                         | 10 PSI  |
| Max. body pressure                              | 15 PSI  |
| Max. close-off pressure                         | 15 PSI  |
| Electrical ratings (+10% / -15%)                | 110 - 120 VAC @ 50 - 60 Hz (others available depending on body size)  |
| Enclosure rating                                | NEMA Type 4 for indoor use<br>NEMA Type 12 for outdoor use  |
| Operating time                                  | 100 % duty cycle  |
| Closing time                                    | < 1 s   |
| Opening time (to max. flow)                     | SV: < 1 s<br>SV-DLE: Adjustable 10 - 20 s @ 70 °F   |
| Ambient temperature rating                      | -40 °F to +140 °F (-40 °C to +60 °C)  |
| Installation position                           | Safety valve upright vertical to horizontal   |
| Test ports &<br>System accessory mounting ports | G 1/8 ISO 228 ports available on both sides.<br>See sales literature for valve specifics.   |
| Proof of Closure Switch<br>on /614 models       | Factory mounted & calibrated; SPDT switch with indication lamps;<br>- AC max. 10 A resistive @ 120 VAC<br>- AC max. 8 A inductive @ 120 VAC |
| Capacities @ 1 in. W.C.<br>pressure drop        | 300 - 2,250 CFH Natural Gas   |

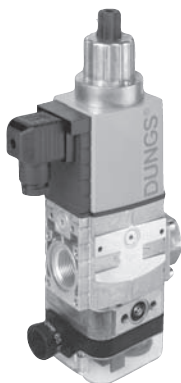

SV-DLE 1005/614

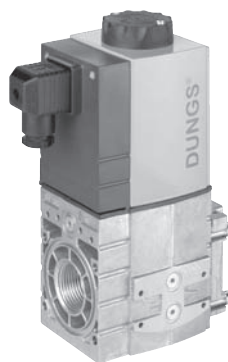

SV 1010/604



SV 1010/614

The MVD/6 and the MVDLE/6 are electrically operated normally closed, automatic safety shutoff valves for gas burners and gas appliances.

- MVD/6 is fast opening and closing. MVDLE/6 is slow opening and fast closing.

- Optional field installable visual indicator (VI) or CPI 400 with indication lamps and SPDT interlock switch for valve position.

### Application

The MVD/6 and MVDLE/6 are recommended for industrial and commercial heating applications that require one safety shutoff valve or two safety shutoff valves in series. The MVD/6 and MVDLE/6 safety shutoff valves are suitable for natural gas, propane, butane, air and inert gases.

## Specifications

|   |  |
|---|--|
| <b>Pipe size / Thread</b>                               | 1/2" - 3" NPT  |
| <b>Max. operating pressure</b>                          | MVD/6 7 PSI @ UL, FM<br>MVD/6 5 PSI @ CSA<br>MVDLE/6 3 PSI @ UL, FM<br>MVDLE/6 2 PSI @ CSA |
| <b>Max. body pressure</b>                               | 15 PSI (FM)  |
| <b>Max. close-off pressure</b>                          | 7 PSI (UL, FM); 5 PSI (CSA)  |
| <b>Electrical ratings (+10% / -15%)</b>                 | 110 - 120 VAC @ 50 - 60 Hz (others available depending on body size)                       |
| <b>Enclosure rating</b>                                 | NEMA Type 12   |
| <b>Operating time</b>                                   | 100 % duty cycle   |
| <b>Closing time</b>                                     | < 1 s  |
| <b>Opening time (to max. flow)</b>                      | MVD/6: < 1 s<br>MVDLE/6: Adjustable 10 - 20 s @ 70 °F                                      |
| <b>Ambient temperature rating</b>                       | -20 °F to +140 °F (-30 °C to +60 °C)   |
| <b>Installation position</b>                            | Safety valve upright vertical to horizontal  |
| <b>Test ports &amp; System accessory mounting ports</b> | 1/4 NPT ports available on both sides.<br>See sales literature for valve specifics         |
| <b>Capacities @ 1 in. W.C. pressure drop</b>            | 300 - 2,250 CFH Natural Gas  |



MVD 520/6



MVDLE 205/6

The valve proving systems - Model VPS 504 S06 available for the DMV/SV series modular automatic valves and model VDK 200A available for stand alone valves test and verify that two automatic shutoff valves in series are fully closed before either a system start-up and/or after system shutdown when wired and interlocked to a suitable flame safeguard control.

The valve proving system will halt the start-up sequence to a burner if it detects an open automatic shutoff valve, thus preventing ignition under potentially dangerous conditions.

### Application

The valve proving systems are recommended for industrial and commercial heating applications. Some authorities

having jurisdiction accept the VPS in lieu of "proof of closure" when integrated with the preignition system and/or in lieu of a vent valve when it checks the valves at start up and shut down. It can also be used as a valve seat tightness check when used within its capabilities. The VPS is suitable for natural gas, propane, air and inert gases. Not suitable for butane gas.

## Specifications

|   |  |
|---|--|
| <b>Pipe size / Thread</b>               | 1/4" NPT (VDK only)  |
| <b>Max. operating pressure</b>          | 7 PSI for VPS @ CSA<br>5 PSI for VDK @ CSA   |
| <b>Max. body pressure</b>               | 10 PSI   |
| <b>Max. close-off pressure</b>          | 7 PSI - VPS; 5 PSI - VDK   |
| <b>Electrical ratings (+10% / -15%)</b> | 120 VAC @ 60 Hz (others available)   |
| <b>Power ratings</b>                    | Test period: 60 VA; In operation: 17 VA - VPS<br>Test period: 80 VA; In operation: 20 VA - VDK   |
| <b>Enclosure rating</b>                 | NEMA Type 12   |
| <b>Operating time</b>                   | 100 % duty cycle, max. 20 test cycles/h - VPS<br>100 % duty cycle, max. 15 test cycles/h - VDK   |
| <b>Ambient temperature rating</b>       | + 5 °F to +140 °F (-15 °C to +60 °C) VPS<br>+15 °F to +140 °F (-10 °C to +60 °C) VDK   |
| <b>Installation position</b>            | Mounts directly to DMV via mounting screws (included) - VPS<br>Upright vertical to horizontal - VPS<br>Upright to horizontal, not inverted - VDK   |
| <b>Accessory<br/>CM 100, CM 101</b>     | The DUNGS CM 100 and CM 101 incorporate the relays and logic necessary to operate a Valve Proving System on a system start up and after shutdown when wired <b>and</b> interlocked with a suitable flame safeguard control. When a Valve Proving System is integrated with the CM 100 or CM 101, the Valve Proving System can be used in lieu of a vent line when accepted by the authority having jurisdiction. |



VDK 200A S02



VPS 504 S06

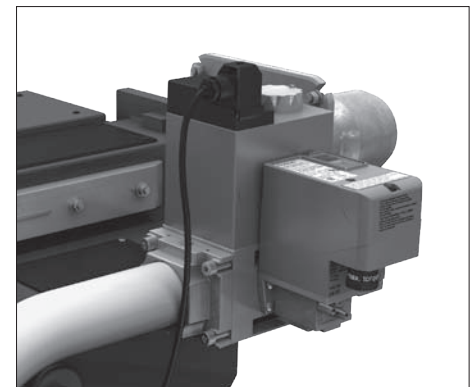

VPS & Burner

The GAO-, GMH-, and GML-A2... pressure switches are compact ventless pressure switches for direct mounting to DUNGS modular valve train components and the SV valve.

- GAO-, GMH- and GML-A4... pressure switches are compact pressure switches with 1/4" NPT threaded connections.

- A2 & A4 series pressure switches are suitable for making and/or breaking a circuit when the medium's pressure changes relative to the set point. The set point can be set in the field by an adjustable dial with an integrated scale.
- GAO is an automatic reset pressure switch, while the GMH and GML are manual reset pressure switches.

### Application

The DUNGS series of pressure switches are recommended for industrial and commercial heating applications with the DUNGS DMV dual modular valves or with 1/4" NPT connections. The GAO-, GMH-, and GML-A2 & A4... pressure switches are suitable for natural gas, propane, butane, air and other inert gases.

## Specifications

|   |  |  |
|---|--|--|
| <b>Pressure connection</b>                          | A2- O-ring flange connection on underside of pressure switch<br>A4- Standard: 1/4" NPT female thread centered, underside   |  |
| <b>Max. operating pressure;<br/>Set point range</b> | GAO-A2 or -A4-4-2, 3, 5, 6:<br>GMH-, GML-A2 or -A4-4 and -6:<br>GAO-, GMH- and GML-A2 or -A4-4-8:  | 7 PSI; 0.16 to 60 in. W.C.<br>7 PSI; 0.16 to 60 in. W.C.<br>14 PSI; 40 to 200 in. W.C. |
| <b>Max. body pressure</b>                           | 15 PSI   |  |
| <b>Electrical ratings (+10% / -15%)</b>             | AC eff. min. 24 V max. 120 V<br>DC min. 24 V max. 48 V   |  |
| <b>Current ratings</b>                              | Silver (Ag) contact ratings<br>AC 10 A resistive @ 120 VAC<br>AC 8 A inductive @ 120 VAC<br>DC min. 20 mA @ 24 VDC<br>DC max. 1 A @ 48 VDC   | Gold (Au) contact ratings<br>DC min. 5 mA @ 5 VDC<br>DC max. 20 mA @ 24 VDC            |
| <b>Electrical connection</b>                        | Screw terminals via 1/2" NPT conduit connection  |  |
| <b>Enclosure rating</b>                             | NEMA Type 4  |  |
| <b>Ambient temperature rating</b>                   | <b>GAO-, GMH- and GML-2 to -6 series</b><br>Ambient temperature -40 °F to +140 °F (-40 °C to +60 °C)<br>Medium temperature -40 °F to +140 °F (-40 °C to +60 °C)<br><b>GAO-, GMH- and GML-8 series</b><br>Ambient temperature -22 °F to +140 °F (-30 °C to +60 °C)<br>Medium temperature -22 °F to +140 °F (-30 °C to +60 °C) |  |
| <b>Installation position</b>                        | ±15% switching point deviation referred to set point, adjusted as pressure rises, vertical diaphragm position.   |  |



- AA-... Compact pressure switches for automatic burner controls.
- AA-A1... Pressure switches that are factory set with hose connections.
- AA-A2-4... Pressure switches that are field adjustable and feature hose connections.
- AA-A2-6... Pressure switches that are field adjustable with NPT threaded connections also include a test button in the lower housing.

## Application

Differential pressure monitoring in combustion air proving, ventilation and air-conditioning systems. The AA-... can be used as a pressure, vacuum or differential pressure switch for air and non-aggressive gases. These switches are not suitable for natural gas, propane, butane and other combustible gases.

## Specifications

|   |  |
|---|--|
| <b>Pressure connection</b>                          | <b>AA-A1; AA-A2-4</b><br>0.16" (4 mm) dia. positive and negative<br><b>AA-A2-6</b><br>1/4" NPT positive; 1/8" NPT negative<br>5/32" (4.6 mm) test connection |
| <b>Max. operating pressure;<br/>Set point range</b> | <b>AA-A1</b> 1.5 PSI; 0.16 to 20 in. W.C.<br><b>AA-A2-4 / 6</b> 7 PSI; 0.16 to 60 in. W.C.   |
| <b>Electrical ratings (+10% / -15%)</b>             | AC eff. min. 24 V max. 120 V<br>DC min. 24 V max. 48 V   |
| <b>Current ratings</b>                              | AC 5 A resistive @ 120 VAC<br>AC 2.5 A inductive @ 120 VAC<br>DC min. 20 mA @ 24 VDC<br>DC max. 1 A @ 48 VDC   |
| <b>Electrical connection</b>                        | <b>AA-A1</b> 1/4 x 1/32" (6.3 x 0.8 mm) flat male terminals<br><b>AA-A2</b> Screw terminals via 1/2" NPT conduit connection                                  |
| <b>Enclosure rating</b>                             | <b>AA-A1</b> NEMA Type 1 or 12 depending on optional cover<br><b>AA-A2-4</b> NEMA Type 4   |
| <b>Ambient temperature rating</b>                   | <b>AA-A1; AA-A2-4 or -6</b><br>Ambient temperature -40 °F to +140 °F (-40 °C to +60 °C)<br>Medium temperature -40 °F to +140 °F (-40 °C to +60 °C)           |



AA-A2-4...



AA-A1...

The FR... series pressure regulators, are spring-loaded pressure regulators with adjustable setpoint that feature an internal sensor for regulating output pressure.

- FRI 7../6: Modular design, directly mounts to DMV valves - Constant output pressure with integrated 50 micron filter.
- FRS available as Line Pressure Regulator or as Gas Appliance Pressure Regulator.

- FRS 7../6 Threaded connections - Constant output pressure
- FRS 5... Flanged connections - Constant output pressure
- FRG 7../6 Threaded connections - Ratio Regulator/ Zero Governor
- FRNG 5...ISO flanged connections - Ratio Regulator/ Zero Governor
- Lock-up type regulators & vent limiter.

### Application

The FR... series gas pressure regulators are recommended for industrial and commercial heating applications and are suitable for natural gas, propane, butane, air and inert gases.

## Specifications

|  |   |
|--|---|
| <b>Pipe size / Thread</b>                              | <b>FRI 7../6</b> Modular mount or 1/2" to 2" stand alone - flanges required.<br><b>FRS 7../6</b> NPT 1/2" to NPT 3"<br><b>FRS 5...</b> DN 40 to DN 150 - ISO Flanged<br><b>FRG 7../6</b> NPT 1/2" to NPT 3" and FRNG 5... ISO Flanged   |
| <b>Input pressure range;<br/>Output pressure range</b> | <b>FRI 7../6</b> 7 PSI; +1 to +60 in.W.C.<br><b>FRS 7../6</b> 10 PSI; +1 to +80 in.W.C.<br><b>FRS 5...</b> 7 PSI; +1 to +80 in.W.C.<br><b>FRG 7../6</b> 7 PSI; -1.2 to 110 in.W.C.  |
| <b>Max. body pressure</b>                              | <b>FRI 7../6; FRS 5...; FRG 7../6</b> 10 PSI<br><b>FRS 7../6</b> 15 PSI<br><b>FRNG 5...</b> 10 PSI  |
| <b>Ambient temperature rating</b>                      | <b>FRI 7../6; FRG 7../6</b><br>+5 to +150 °F up to 7 PSI<br>-40 to +150 °F up to 2 PSI and outlet 3 - 60" W.C.<br><b>FRS 7../6</b><br>+5 to +150 °F up to 10 PSI<br>-40 to +150 °F up to 2 PSI and outlet 3 - 60" W.C.<br><b>FRS 5...</b> +5 to +150 °F (-15 to +70 °C)<br><b>FRNG 5...</b> +5 to +150 °F (-15 to +70 °C) |
| <b>Installation position</b>                           | Regulator dome from vertically upright to lying horizontally  |
| <b>Vent Line / Vent limiter</b>                        | Incorporates factory installed vent limiter. Venting required, unless otherwise accepted by the authority jurisdiction.   |
| <b>Capacities @ 1 in. W.C.<br/>pressure drop</b>       | 200 - 15,000 CFH Natural Gas  |

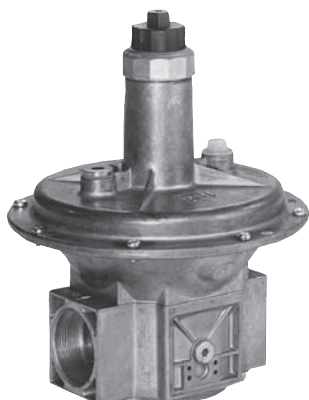

FRG 725/6

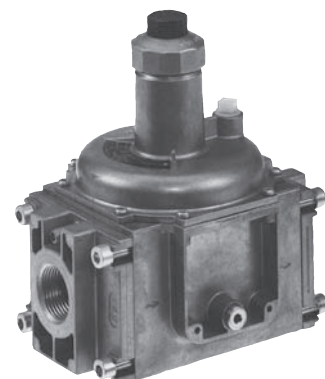

FRS 710/6 &amp; FRS 5050

FRI 705/6  
(Shown with optional flanges)

The DMA actuator drives from 0° to 90° via a 4 - 20 mA input signal and features integrated 4 - 20 mA output terminals. The DMA can move in any direction and stop anywhere over the entire 90° stroke. The DMA is available in three different set speeds: 6 s, 12 s, and 30 s. The DMA has one independent, field adjustable auxiliary SPDT switch and two field adjustable limit switches.

The DUNGS DMK butterfly control valve operates from 0° to 90° degrees in either direction. Inlet-side male thread and outlet-side female thread enable a space-saving assembly directly to most DUNGS valves.

### Application

The DMA is used to automatically modulate the amount of gas supplied to the burner.

The DMK are recommended for industrial and commercial heating applications for modulating gas or air supply to burners. The DMK control valves are suitable for natural gas, propane, butane, air and other inert gases.

## Specifications - DMA / Actuators

|                                  |  |
|----------------------------------|--|
| Electrical ratings (+10% / -15%) | 110 - 120 VAC @ 50 - 60 Hz (UL and CSA)            |
| Power rating                     | Holding: max. 2.0 VA - Operation: max. 5.4 VA      |
| Enclosure rating                 | NEMA Type 1 (Optional NEMA type 4 cover available) |
| Electrical connection            | Screw terminals with 1/2" NPT conduit connection   |
| Operating time                   | 100 % duty cycle                                   |
| Ambient temperature rating       | +15 °F to +120 °F (-10 °C to +50 °C)               |
| Installation position            | Multipositioned                                    |

## Specifications - DMK / Modulating valves

|  |   |
|--|---|
| Pipe thread,<br>Male input female output | DN 40 - DN 125 (UL Versions also available)<br>DMK: NPT: 3/4", 1", 1 1/4", 1 1/2", 2" |
| Max. inlet pressure                      | 7 PSI   |
| Max. differential pressure               | 1.5 PSI   |
| Max. body pressure                       | 15 PSI  |
| Ambient temperature rating               | 5 °F to +140 °F (-15 °C to +60 °C)  |
| Installation position                    | Multipositioned   |
| Capacities @ 4 in. W.C.<br>pressure drop | 500 - 5,000 CFH Natural Gas   |



DMA 12B120



DMK 5050

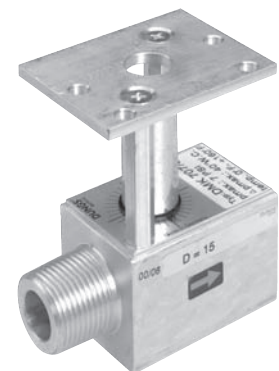

DMK 707/6

The DMV is the main component of the DUNGS Modular Gas Safety System comprised of:

- 1 DMV combines two Automatic shut-off valves in one housing
- 2 GAO (or GMH & GML) Gas pressure switch

- 3 Flanges 1/2" to 2" NPT threaded
- 4 FRI Pressure regulator with built in 50 micron Filter
- 5 Visual indicator

- 6 Proof of closure switch or CPI 400 Closed position indicator switch
- 7 Pilot line connector
- 8 VPS 504 Valve proving system

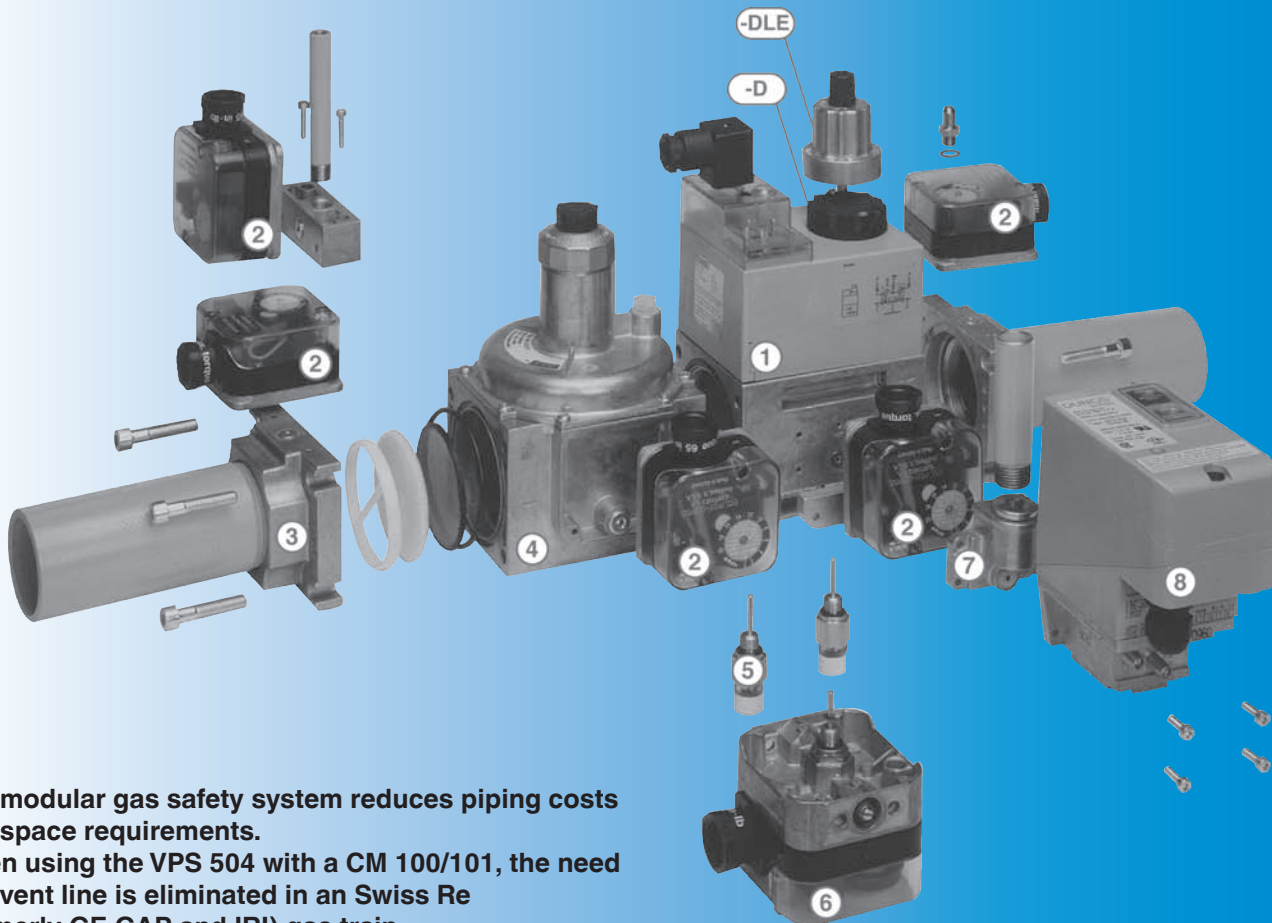

The modular gas safety system reduces piping costs and space requirements.

When using the VPS 504 with a CM 100/101, the need of a vent line is eliminated in an Swiss Re (formerly GE GAP and IRI) gas train.



DUNGS designs, builds and tests high quality fuel trains for just about any application. 50 years in the gas control industry allows DUNGS to be your design partner with experience in Europe, the Americas, Australia and Asia.

### DUNGS Fuel Trains

- Comply with applicable US Standards and European Directives
- Capacities to 4500 kW (150 Mbtu/h)

- Natural gas, propane, butane, air, manufactured gas and other inert gases.
- Prepiped valve trains for landfill gas, digester-gas or biogas also available.

## Specifications

|                             |   |
|-----------------------------|---|
| <b>Electrical ratings</b>   | 120 VAC 50 - 60 Hz, 230 VAC 50 - 60 Hz, 24 VDC                  |
| <b>Enclosure rating</b>     | IP 54 (NEMA Type 12), IP 65 (NEMA Type 4) or hazardous location |
| <b>Input pressure range</b> | Up to 6 Bar (87 PSI)  |

**Delivered fully assembled and pressure tested with certificate, if requested.**

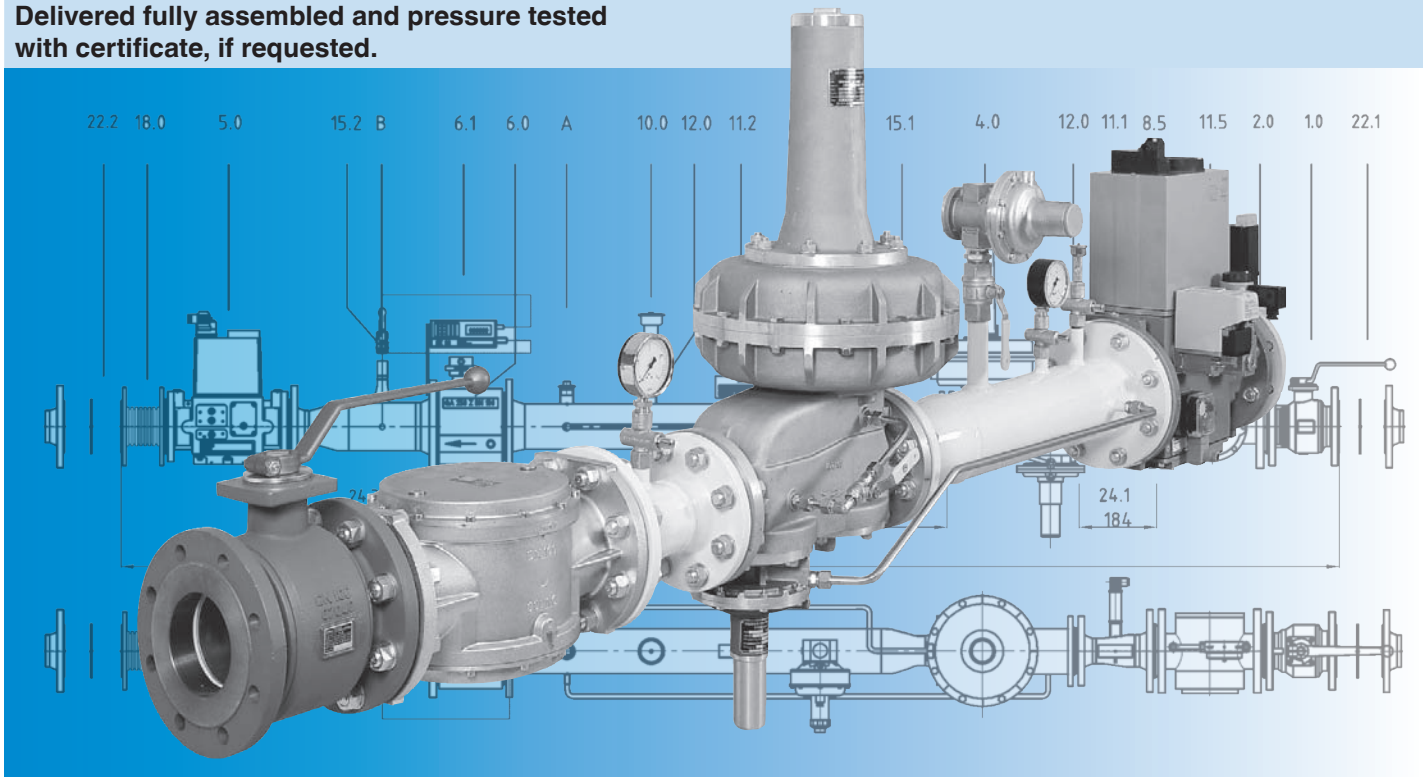

### Manually operated shutoff valves for Flammable Fluids and Gases

Fully ported manual shut-off ball valves with low turning torque. Valve seat and packing are made of Teflon; O-ring is made of Viton.

### Gas Orifice & Venturi Meters

Permit accurate setting of burner air & gas flow for optimum efficiency.

### Electric Actuators

Designed to operate dampers, butterfly valves and similar devices. Torques from 16 in. lb. to 1300 in. lb.

### Ignition Transformers

For reliable ignition of gas burners.

## Specifications

### Manually operated shutoff valves for Flammable Fluids and Gases

CSA certified, UL Listed  
 Pipe sizes (NPT): 1/4" to 3"  
 Ambient temperatures: -40 °F to +300 °F  
 Max. operating pressures (ratings):  
 UL 1/4" to 2" 125 PSIG  
 CSA 1/4" to 2" 5 PSIG

### Gas Orifice Meters

Max. operating pressure: 250 PSI  
 Brass construction: 1/2" to 2"  
 Carbon steel: 2 1/2" to 24"

### Gas Venturi Meters

Max. operating pressure: 250 PSI  
 Brass construction: 1/2" to 1 1/4"  
 Carbon steel: 2 1/2" to 8"

### Electric Actuators

All models are UL listed and CSA approved.

**EMA-** • Two Position

**EMP-** • Position Proportioning 100 Ohm Slidewire Feedback

- Potentiometer Slaved Proportioning, 100-1000 Ohm, Slidewire feedback
- Proportioning, 4-20 mA Input
- High Torque

### Ignition Transformers

Primary 120 or 240 V  
 50 or 60 Hz Models  
 Secondary 6000 V  
 UL listed, CSA approved (120 V-Version)



EMP 454-5



Ball Valve / Orifice



Venturi / Ignition Transformer



[www.dungs.com/usa](http://www.dungs.com/usa)

Karl Dungs Inc.  
3890 Pheasant Ridge Drive NE  
Suite 150  
Blaine, MN 55449, U.S.A.  
Phone 763 582-1700  
Fax 763 582-1799  
e-mail [info@karldungsusa.com](mailto:info@karldungsusa.com)  
Internet <http://www.dungs.com/usa>

Karl Dungs GmbH & Co. KG  
P.O. Box 12 29  
D-73602 Schorndorf, Germany  
Phone +49 (0)7181-804-0  
Fax +49 (0)7181-804-166  
e-mail [info@dungs.com](mailto:info@dungs.com)  
Internet <http://www.dungs.com>